

Instruction Manual

(original)

Installation and Operating Instructions

X-Flow90 Transfer Unit

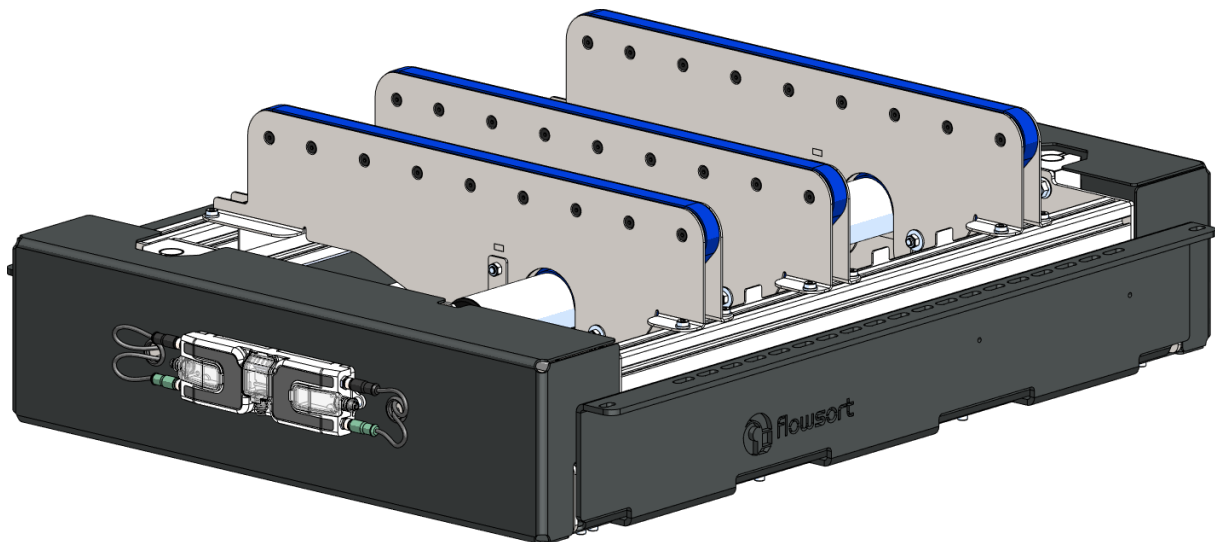

Manufacturer's address:**Flowsort Kft.**

Gyár u. 2

2040 Budaörs

Hungary

T: +36 23 880-977**W:** www.flow-sort.com**E:** info.hu@flow-sort.com**Version: 1.3 – REV1.0****12-MAR-2025**

author: Mikle, István

TABLE OF CONTENTS

TABLE OF CONTENTS	3
SAFETY PRECAUTIONS	4
1.1 General warning.....	- 4 -
1.1.1 Installation	- 4 -
1.1.2 Operations	- 4 -
1.2 General caution.....	- 5 -
1.2.1 Installation	- 5 -
1.2.2 Maintenance	- 6 -
1.3 Symbols.....	- 6 -
1.4 Risk Analysis	- 7 -
PRODUCT INFORMATION	8
2.1 Technical Data Sheet.....	- 8 -
2.2 Product description.....	- 9 -
2.3 Options	- 9 -
PRECAUTIONS BEFORE USE	10
3.1 Explanation part names	- 10 -
3.2 Additional documentation for application	- 10 -
3.3 Staff training	- 10 -
3.4 Safe operation.....	- 10 -
INSTALLATION	11
4.1 General rules.....	- 11 -
4.2 Installation	- 11 -
4.3 Lifting and transportation of the diverters.....	- 12 -
4.4 Assembly/disassembly device vs framework	- 13 -
4.5 Wiring and grounding of the device.....	- 14 -
OPERATION	15
5.1 First checks before operating.....	- 15 -
5.2 During operation	- 15 -
5.3 In case of an accident.....	- 15 -
5.4 Set-up diverting angle.....	- 15 -
MAINTENANCE	16
6.1 Maintenance intervals	- 16 -
6.2 General maintenance information	- 16 -
6.3 Cleaning the belts	- 16 -
6.4 Spare parts.....	- 17 -
6.5 Device inspection	- 18 -
6.6 Removal and replacement of parts	- 19 -
6.6.1 Cover removal/replacement	- 19 -
6.6.2 Belt drive unit removal/replacement.....	- 20 -
6.6.3 Transfer belt removal/replacement	- 21 -
6.6.4 Transfer belt tensioning	- 22 -
6.6.5 Taper bush and timing belt removal/replacement.....	- 23 -
6.6.6 Lift motor removal/replacement.....	- 24 -
6.6.7 Control card removal/replacement.....	- 25 -
6.6.8 Motor driven roller removal/replacement.....	- 26 -
6.6.9 Inductive sensor removal/replacement	- 27 -
6.6.10 Lifting wheel removal/replacement	- 28 -
6.6.11 Pillow block removal/removal.....	- 29 -
6.6.12 Timing belt synchronization	- 30 -
TROUBLESHOOTING	31
7.1 Troubleshooting.....	- 31 -
DECLARATION OF CONFORMITY	32
7.2 CE & UKCA Certification	- 32 -

SAFETY PRECAUTIONS

1.1 GENERAL WARNING



Warning: Indicates an imminently hazardous situation which, if not avoided, will result in death or serious injury.

Do not use the product in an explosive atmosphere, flammable gas atmosphere, corrosive atmosphere, a place exposed to water splashes, or a place close to combustibles. It may cause an electric shock, injury and/or fire.

All work (e.g., installation, connection, operation, maintenance and failure diagnostics) must be done by a qualified and well trained person. Failure to do so may cause a fire, electric shock and/or injury.

Machine movements are very dangerous. Do not conduct operations as moving, installation, connection and maintenance while the power is on. Be sure to conduct such operations after turning off the power in order to prevent injury and/or accidents.

1.1.1 INSTALLATION

Never touch the power supply when installing PGD/control card of the X-Flow90 diverter. It may cause an electric shock and/or injury.

Please check the specifications of the power supply, the voltage 24V ($\pm 5\%$), before wiring. Failure to do so may cause a fire, electric shock, injury and/or breakage.

The diverter shall be incorporated into an emergency stop circuit arranged by the system integrator.

Please make sure that the control circuit has to meet standard EN-IEC 60204-1 and that the emergency stop system must be provided according EN-ISO13850.

1.1.2 OPERATIONS

Do not touch the internal structure during operation to prevent entanglement and/or clamping accidents. Be sure to add instructions such as start/stop, after switching on the power. It may cause an injury and/or accident due to unexpected start-up.

If control card protection function worked, remove the cause prior to release the function. Otherwise, malfunction may occur again and it could result in an accident, injury and/or breakage.

If abnormal noises are being given out from the device, turn off the power switch and cut the power supply immediately to avoid unpredictable accidents. Immediately rectify any defects or damage which occurs.

Do not use the unit in any way beyond its specifications. It may cause an injury and/or breakage.

Safety and danger notices must be fully legible.

1.2 GENERAL CAUTION



Caution: Indicates a potentially hazardous situation which, if not avoided, may result in minor or moderate injury and could cause property damage.

Never store or leave the device outdoors.

Do not climb and/or overload on the product. It may cause an accident and/or breakage.

Do not exceed the maximum load capacity or insert objects into gaps. It may cause an accident and/or breakage. The device must be in a good/safe condition.

Never modify the main unit of the device and control card. It may cause an accident, injury and/or breakage.

Make sure that no liquids can get onto the device. It may cause an electric shock, injury and/or breakage. The device is not provided with dust- and/or waterproof function.

Prevent high impact, such as dropping or striking the device. It may cause an accident and/or breakage.

Do not touch the product immediately after operation. It can get very hot and there is a danger that you may get burned and/or injured.

Wear gloves as many metallic parts are used for the device. Failure to do so may cause an injury.

No loose clothes, jewellery or loose hair allowed when working with this machinery.

Do not install the device in a place with high vibration.

Take measures against gravity fall of the unit loads when the unit is installed at elevated position, i.e. side rails/ guards.

1.2.1 INSTALLATION

Always install the product horizontally and make sure it is well mounted in the framework.

Do not pull, bend or twist the electric cable with unnecessary force. There is a danger of fire or electric shock due to breakage.

The DC power supply must be earthed. It may cause an electric shock in case of a breakdown or electrical leakage.

Keep sufficient working space around the device for maintenance.

Wear protective shoes during installation (gravity fall causing foot injury).

1.2.2 MAINTENANCE

Any damage to the device should be repaired immediately.

Turn off the power and wait a couple of minutes before starting maintenance/inspection/repairs. Make sure you secure the power supply against being switched on again.

Only access the plant where access is allowed and follow safety notices. Always wear protective clothes and/or use safety equipment.

When replacing parts to the device disassemble only the parts as specified in the manual.

Be careful for not getting your fingers caught in the device.

Make sure you will mount covers and tighten screws properly after maintenance/inspection/repair.

1.3 SYMBOLS



Warning: Indicates an imminently hazardous situation which, if not avoided, will result in death or serious injury.



Caution: Indicates a potentially hazardous situation which, if not avoided, may result in minor or moderate injury and could cause property damage.



Note: In order to keep the machine in full performance, comply with all technical requirements for the correct use of the machine.



Info: additional information for optimizing and taking the full advantage of your machine.

1.4 RISK ANALYSIS

Hazard	Cause	Avoidance
Serious injury to the area of the spine/wrist	Excessive physical stress during manual lifting of the products	Use appropriate lifting equipment instead of manually lifting.
Serious injury to hands	Clamping of hands between moving objects	Do not touch the product when it is connected to a power source or when it is operating.
	Catching of clothing/jewellery in moving machine parts during maintenance or operation	Use approved working clothes and remove all jewellery.
	Cut injury due to sheet metal plates	Use approved safety gloves.
Serious injury to head	Catching of hair in moving machine parts during maintenance or operation	Bind long hair together and always use a hairnet.
Serious injury to body	Falling of unit loads while removing from the device after breakdown/emergency stop.	Use of safety shoes (minimum Class SB) Use of safety gloves with grip coating Use of safety straps when lifting unit loads above 25kg.

PRODUCT INFORMATION
2.1 TECHNICAL DATA SHEET

General Data	
Voltage	DC24V
Controller	DC24V – Max. power consumption 0,05kW
Rated Motor Output Current	2.5A x 2 (ECO), 3.5A x 2 (boost and boost-8)
Available Starting Current	3.0A x 2 (ECO), 5.0A x 2 (boost and boost-8)
Max. load capacity	50 kg
Operating ambient temperature	0°C to 40°C
Operating ambient humidity	≤ to 90% (no condensation)
Noise level	< 79dB – Noise level can vary due to surrounding conditions
Installation site	Indoors
Cycle time	
400mm width	~1,7s
600mm width	~2,2s
Dimensions	
Base unit width	394mm (called 400) or 594mm (called 600),
Base unit length	708mm (called 700) or 868mm (called 850)
Sorting angle	± 90
Weight	
Base unit (without belt units and mounting flanges)	~28,5 kg – ~40 kg
Belt unit (400mm, 600mm)	~2,1 kg, ~3,1 kg
1x mounting flange (depends on size)	~3,3 kg – ~9,5 kg
Lift assembly	
Lift motor	Pulseroller PGD-Ai 24V gear ratio: 67
Lift stroke	15mm
Lift roller material	Yellow PU, 92 Shore A
Lift roller bearing	Precision ball bearing 6301 2RS
Transmission belt on motor	HTD 5M 325-15
Transmission belt on lift shafts	HTD 5M 575-15 (400), HTD 5M 975-15 (600),
Lifting time	Minimum 0,7s (Eco mode)
Belt drive assembly	
Belt motor	Pulseroller Senergy-Ai 24V speed code: 25
Belt speed	0,05 – 0,41 m/s (Boost mode)
Belt coating	Blue PVC, 70 Shore A (±5%)
Belt roller material	POM-C
Belt roller bearing	Precision ball bearing 6002 2RS
Transfer belt length	950mm (400), 1345mm (600)
Transfer belt width	16mm
Minimum conveyor roll pitch	70mm
Minimum conveyor roller gap	26mm
Maximum conveyor roller diameter	80mm

2.2 PRODUCT DESCRIPTION

The device is used for diverting unit loads, preferably with smooth bottom surfaces, at 90° angle onto chutes to the right or to the left.

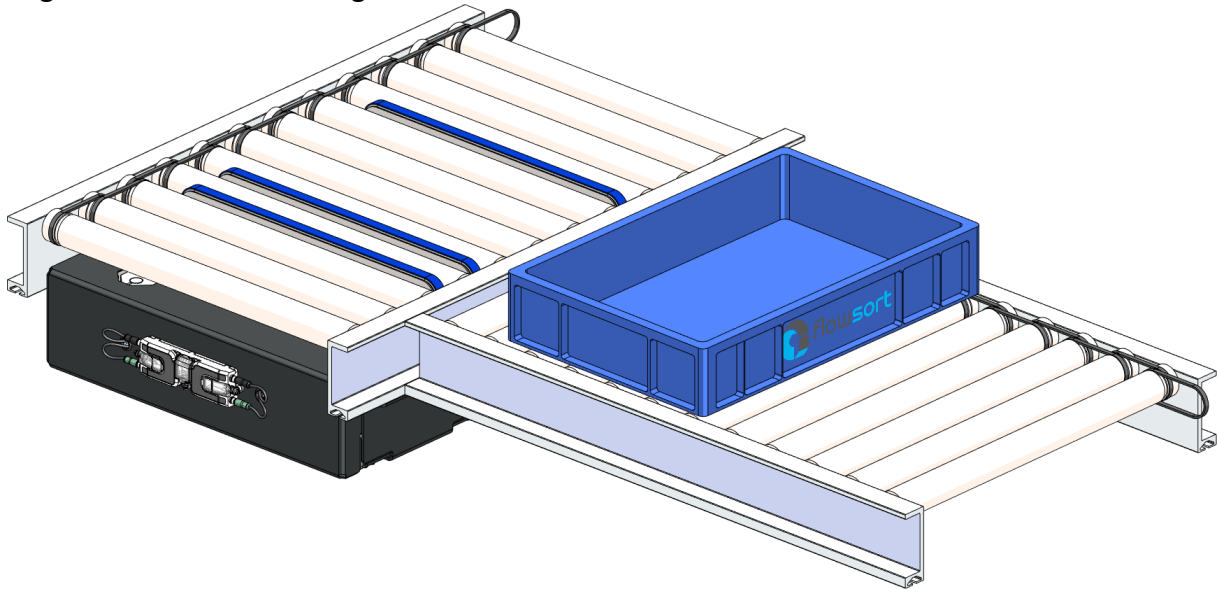

2.3 OPTIONS

The device has a variety of options which will affect dimensions and weight. Apart from diverter speed and divert angles, which will not affect dimensions, the possible frame widths can differ. The options are regarding width: 400mm or 600mm. Length can be 700mm or 850mm. Amount of belt drive units: 2 - 4 pcs. All widths can be extended with a custom made flange that helps the attachment to the conveyor frame. Minimum BF (between frame) distance: 400mm.

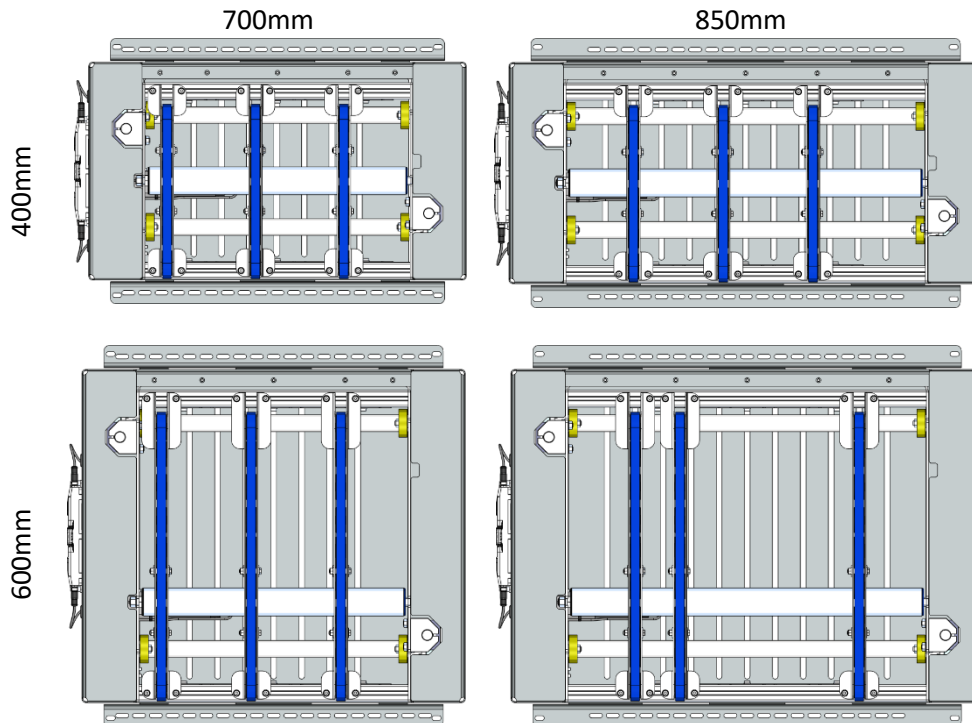

PRECAUTIONS BEFORE USE

3.1 EXPLANATION PART NAMES

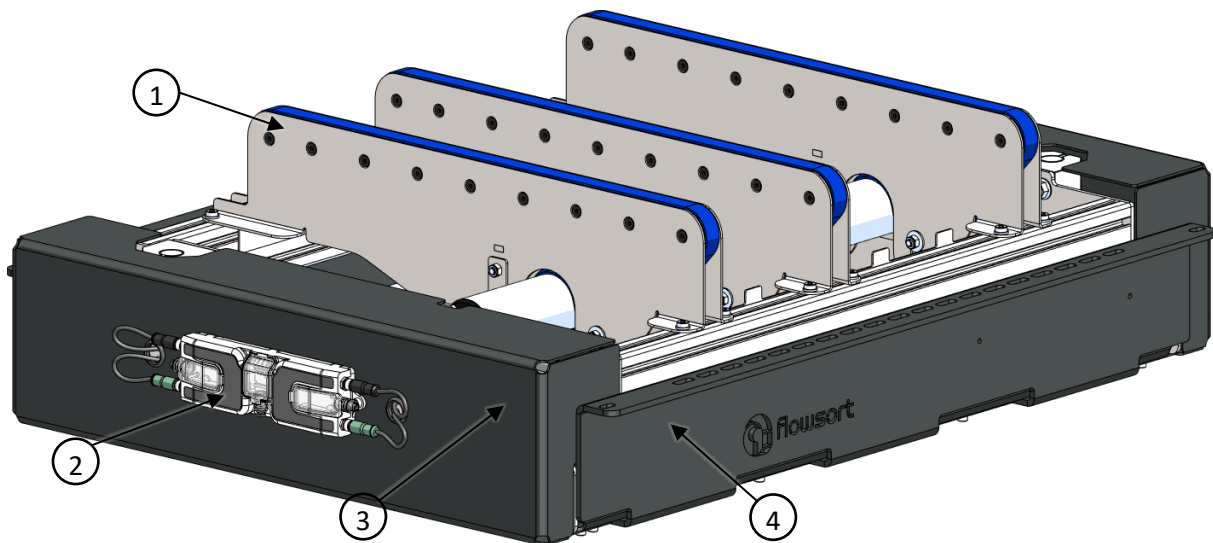

- 1 Belt drive unit
- 2 Control card
- 3 Covers
- 4 Flange

3.2 ADDITIONAL DOCUMENTATION FOR APPLICATION



- General and local rules for accident prevention.
- Law on the Protection of staff.
- Requirements for environmental protection.
- Compliance with established house rules.

3.3 STAFF TRAINING



- You have completed the required training and you are fully aware of the possible risks.
- You are aware of the predefined house rules and have been instructed by the responsible operator.
- You understand the contents of this documentation.

3.4 SAFE OPERATION



- Please ensure that there are no persons or obstacles in the danger areas.
- When there is a threat of danger make sure you shut down operation at once.
- Regular monitoring and maintenance keeps your factory ready for use and safe.
- Safety and hazard statements must be fully legible.
- Immediately correct any defects or damages.
- Wearing and using protective equipment.

INSTALLATION

4.1 GENERAL RULES

Before starting assembly take the following into account:

- Make sure you install the device as designed in the overall layout.
- Check packaging for damages before unpacking the device.
- During unpacking make sure you do not damage the device and you are using proper tooling. See crate for first instructions.
- Make sure you will align the system together with the rest of the system standing around it.
- Please make sure you clean the worksite after assembly and before testing. Do not leave any spare parts or tools in the work site and surrounding area, it can cause damages.
- Perform a full risk analysis of the entire installation as the 24V right angle diverter itself is not a complete system.

Assembly and installation can only be done by properly instructed personnel. This personnel must be under the supervision of a manager who is technically competent concerning the following:

- Knowhow concerning the device and its use.
- The dangers in relation to the assembly of heavy machinery.
- The risks related to incorrect installation.
- The adjustments required for correct installation.

4.2 INSTALLATION

The installation manual provided by FlowSort B.V. is an overall guide line in how to install the modules. Always adapt the installation manual to the national and local safety rules and restrictions.

FlowSort B.V. will always deliver the device pre-assembled. Installation on site only consist out of the following:

- Mounting into frame work
- Cable/wiring (24VDC and data)



If any adjustments are made, both to the device itself as to the position within the framework, then FlowSort B.V. will not take responsibility for the machinery because it represents unintended use of the device.

For wiring instructions please check <https://www.pulseroller.com/downloads>



Make sure that each module section is well supported before you mount the device into the framework. After assembly do not move this framework as it could cause damages to the framework. After installation always mount the leg set to the floor or to a solid construction. It reduces movement/vibration during operation.

4.3 LIFTING AND TRANSPORTATION OF THE DIVERTERS

The device can be lifted by the slotted holes of the flanges. The diverters can also carefully be transported by supporting from below.

Gently support the diverters from below to get to the right position. Make sure not to bump in the bottom covers or move the diverters sideways.

Always pick the diverters up by the two flanges.

*Lifting and transporting the diverters is at own risk and own responsibility.
Be careful while moving the diverters over the ground and through the air!*



Do not lift the device by its belt units or covers! Lifting by the upper part of the mechanism will cause disintegration of the device!

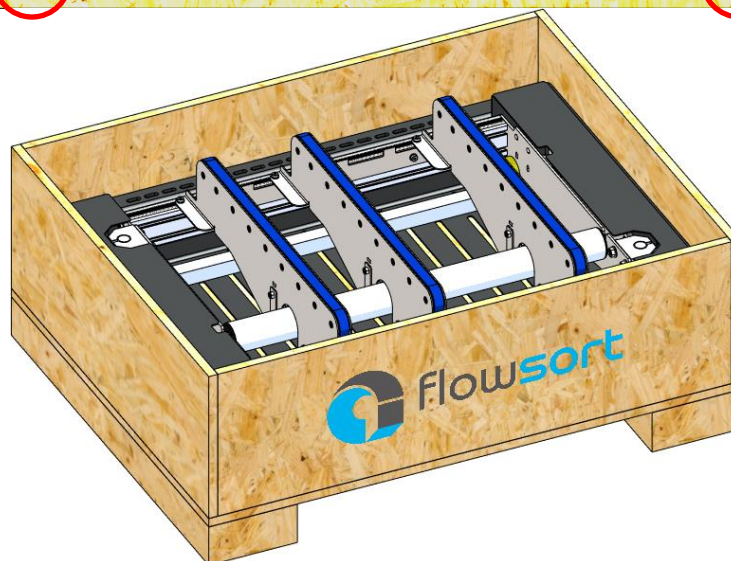
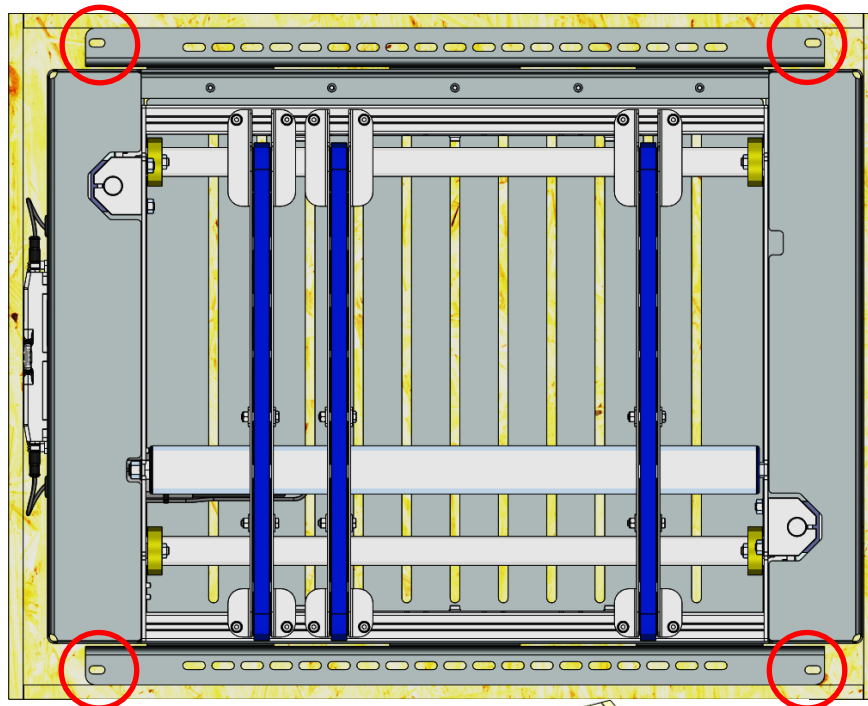

4.4 ASSEMBLY/DISASSEMBLY DEVICE VS FRAMEWORK

The device can be mounted into the frame work by its flanges. Mounting hardware is not included in the package. Default bolt size: M8 (different size on request).



We recommend you to use a +5mm height of the diverter belts relative to the TOR/TOB. The gap between the rollers and the belt drive units should be equal on both sides. The rollers may not hit the diverter otherwise it could get damaged.

Lift up the device with appropriate lifting equipment and align the holes of the flange with the framework! Use at least 3x M8 fasteners on each side!

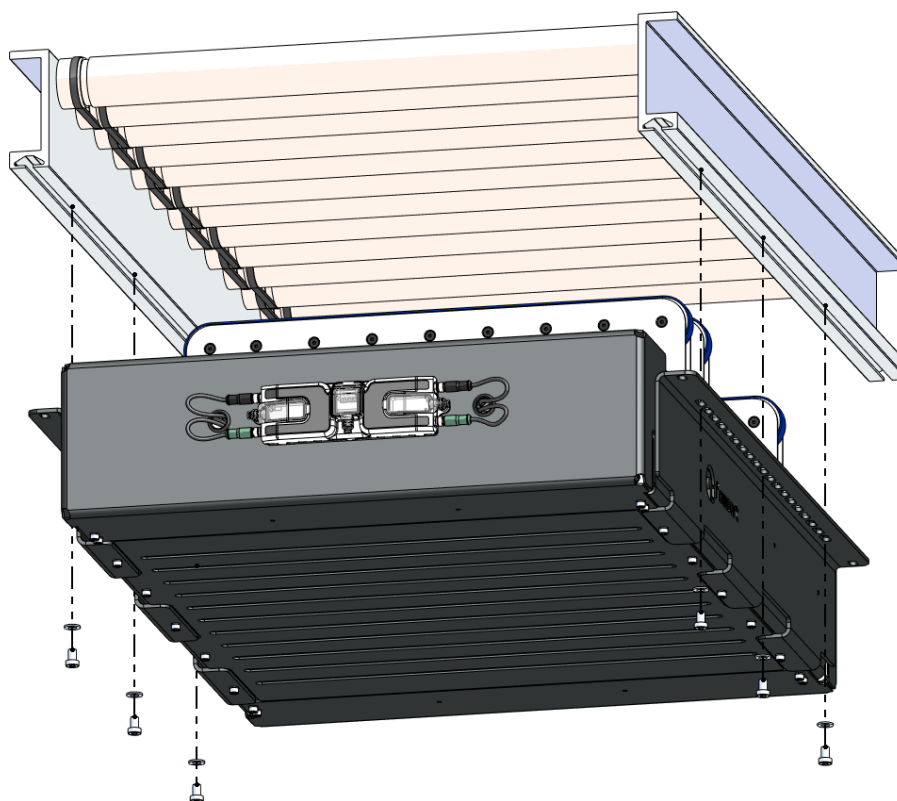

4.5 WIRING AND GROUNDING OF THE DEVICE

The control card can be found at the short side of the device module. Make sure all cables are connected properly. Failure to do so may lead to malfunction.

Sensors and motors are already pre-cabled during production. Wiring the control card, like power supply and PLC-communication, has to be done according to the Integration Manual. Flowsort will provide the integration manual on order or on request.

When using the diverters, a higher electrical voltage build-up is generally not to be expected. However, the dust and the friction on the belt can cause a voltage build-up. Therefore Flowsort states that each diverter is connected to a main ground of the electrical connection according to DIN VDE 0100 (VDE 0100).

This is a protection against possible electrical sparking, dust accumulation and it also protects the motor electronics from overvoltage.

Control card can be relocated to the bottom of the covers or to the flanges:

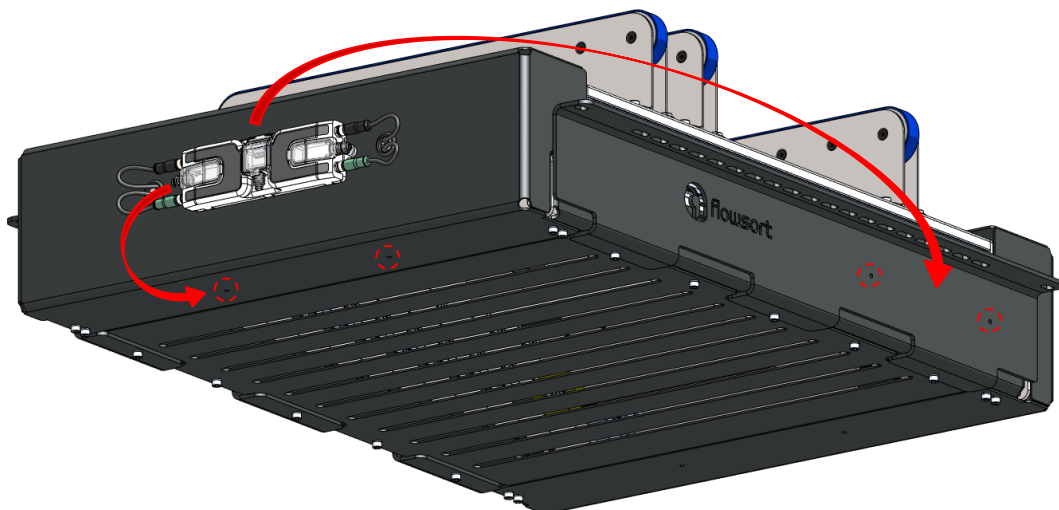

OPERATION

5.1 FIRST CHECKS BEFORE OPERATING



- When connecting the device to another system, you will have to perform a risk analysis of the entire installation.
- Always check the installed modules for damages before starting operation. If there are visible damages please inform operating supervisor immediately. Do not start operation, see maintenance.
- Check the area for material that should not be there, and remove this when it's there (packaging material, tools, debris, etc.).
- Check if all signs/restrictions are in place (max. load capacity and restriction for use).
- Check if all personnel is properly instructed before working with or near the device.

5.2 DURING OPERATION

Shut down the whole system if any of the following occurs:



- A broken or damaged component.
- Damage to structural components such as frame, side guiding and leg set.
- Doubtful noise from any of the components.
- Liquids are on the systems.
- Unit loads on the conveyor system are getting stuck.

5.3 IN CASE OF AN ACCIDENT



- Press in the emergency stop of the system where the device is located.
- Secure the area and set up appropriate signage.
- In the event of an accident: provide first aid and let someone else call the emergency services.
- Inform qualified personnel and/or operating supervisor.
- Have the system repaired by qualified maintenance personnel.
- Do not use the device until it has been approved by qualified maintenance personnel.

5.4 SET-UP DIVERTING ANGLE

The diverting angle is a fixed right angle. The diverter has an inductive sensor for the top and bottom position. Setting up the timing and speed will be done in the software. Please contact Flowsort B.V. for the right function blocks. The function blocks are available in multiple brands of PLC-suppliers (i.e. Siemens, Omron, Allen Bradley and others).

MAINTENANCE

6.1 MAINTENANCE INTERVALS

Damage can occur if maintenance is not performed as planned. If the maintenance intervals are not followed as suggested, the warranty expires. Flowsort B.V. has defined the following maintenance intervals:

ACTIVITY	INTERVAL
Check for possible damage to the conveyor components	daily
Noise testing on moving parts	daily
Clean the machine from contamination	daily
Check screw connections	monthly
Check the condition and function of the side guide	monthly
Check that the protective device is completely and properly installed	monthly
Check the drive for oil loss or excessive noise	monthly
Check the sensor system for condition and function. Remove any contamination and tighten if necessary	monthly
Check the condition and running of the belts: - Is the belt tension sufficient? - Are there any tears or cuts in the belt	quarterly
Lubricate bearings	yearly

During these maintenance periods the device should be disconnected from the power supply. Please clean and look closely for wear during inspection. If errors are found during inspections, they must be corrected immediately.

6.2 GENERAL MAINTENANCE INFORMATION



Clean the outside of the device with a dry cloth. Do not use aggressive cleaning agents as it could affect the components resulting in a possible oxidization of the parts. Never use water for cleaning!

Secure the working area and shut down the system and apply appropriate signage. Make sure nobody can start up the system during maintenance.

Make sure maintenance is carried out by qualified personnel who are familiar with the instruction manual and procedures.

Wear personal protective equipment.

If in doubt, contact the supplier or manufacturer of the parts.

6.3 CLEANING THE BELTS

Due to dust and small splinters of damaged products (i.e. cardboard dust, loosened tapes, etc.) the belts can get dirty. The dirtiness on the belts can reduce the grip on the transported products. With real dirt on the rollers, the sortation movement can be affected. Therefore, the belts need to be cleaned.

To clean the blue wheels, use a degreaser or another kind of liquid which doesn't affect the blue TPU of the wheels.

6.4 SPARE PARTS

All electronic and drive parts are from preferred suppliers. Please have a look on their website for additional maintenance and cleaning information.

Please have a look at our recommended spare part list in this document.

Main spare parts for the device:

nr.	description part number	sorter size	nr.	description part number	sorter size
1	belt drive unit S000093.400 S000093.600	sorter width 400mm 600mm	7	guide roller V000095	all
2	transport belt V000098.880 V000098.1230	sorter width 400mm 600mm	8	sensor cable E000006	all
3	timing belt – lifting V000097.575 V000097.975	sorter width 400mm 600mm	9	motor for belt drive E000039.700 E000039.850	sorter length 700mm 850mm
4	timing belt – motor V000097.325	all	10	motor for lifting E000038	all
5	control card E000003 (ConveyLinx-Ai2) E000004 (MotionLinx-Ai)	all	11	sensor E000005	all
6	pillow block V000085	all			

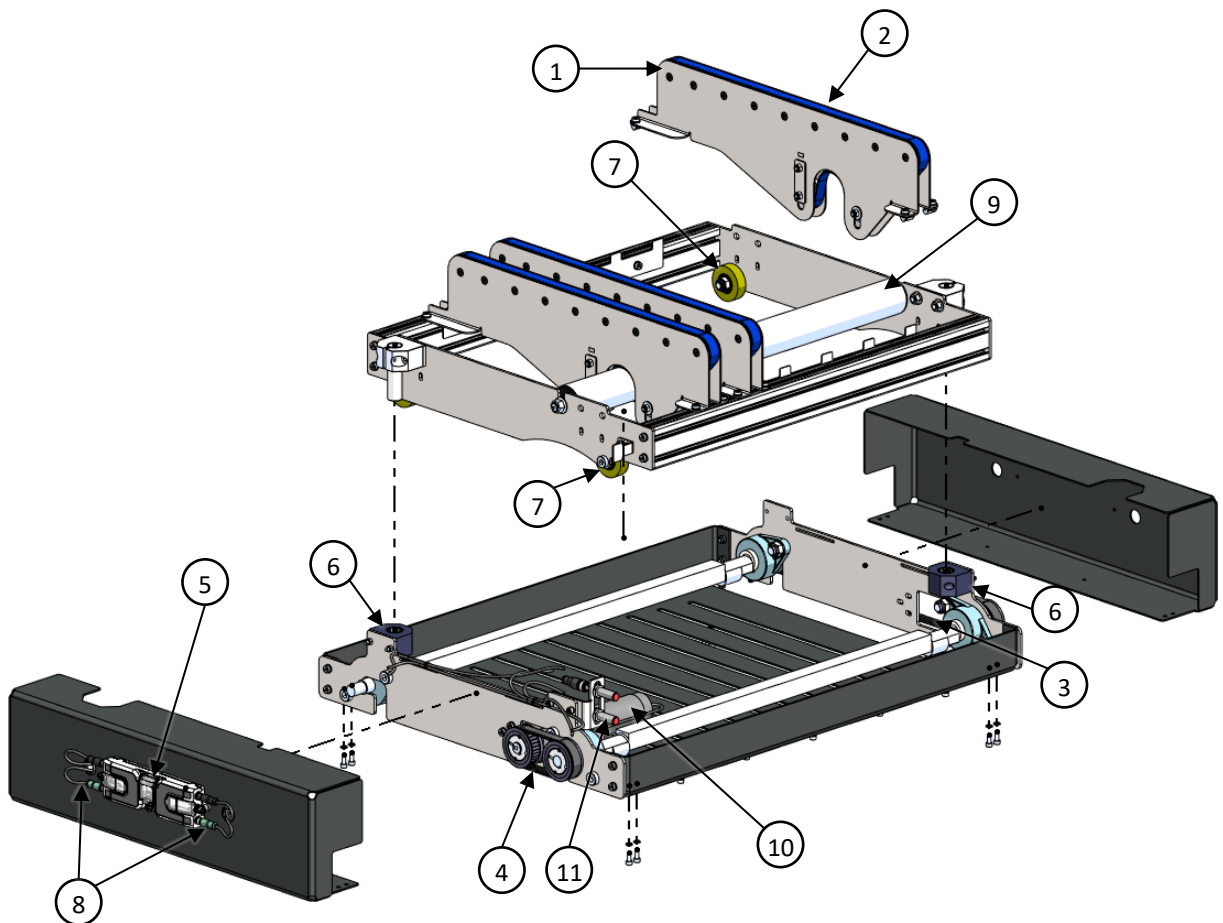

6.5 DEVICE INSPECTION

Item	Inspection	Outcome	Action to execute
lift motor	visual check sound check mounting check	damaged cable abnormal/scratchy noise bolts are too loose	Replace the motor. Replace the motor. Tighten bolts with torque wrench.
belt drive motor	visual check sound check mounting check	damaged / dented surface dirtiness abnormal/scratchy noise bolts are too loose	Replace the motor. Clean the surface of the motor. Replace the motor. Tighten bolts with torque wrench.
belt drive unit	visual check sound check	damaged transport belt leaking bearings abnormal/scratchy noise	Replace the transport belt. Replace the belt drive unit. Replace the belt drive unit.
bearings	visual check sound check	missing covers abnormal/scratchy noise	Replace the bearing. Replace the bearing.
control card	visual check	no power loose cables dirtiness damaged	Check power supply. Fasten loose cables and check wiring. Clean control card. Replace control card.
sprocket	visual check	damaged sprocket	Replace the sprocket
inductive sensor/cable	visual check mounting check	LED off sensor too loose	Check wiring and/or cable connection. Check power supply. Replace sensor. Tighten nuts.
timing belt	visual check	damaged/broken belt	replace timing belt
pillow block	visual check sound check	scratched pin surface dirtiness abnormal/scratchy noise	Replace the pin. Clean off the dirt build-up. Replace the pillow block.
lift mechanism	mounting check	stuck linear guides	Check the position of the lift shafts.

6.6 REMOVAL AND REPLACEMENT OF PARTS

The parts in the diverters need to be repaired and replaced as soon as possible.



Make sure the device is disconnected from the power supply during cleaning, maintenance and/or replacements.

6.6.1 COVER REMOVAL/REPLACEMENT

Step 1

Disconnect all cables to the control card. Please keep in mind how the cables are connected to the control card.

Step 2

Remove all the 4 M5 screws to remove the side cover plates.

Step 3

Remove all the 4 M5 screws to remove the bottom cover plate.

Put all screws in a bag not to lose them.

Step 4

Replacing the covers can be done by repeating the steps in reverse order.

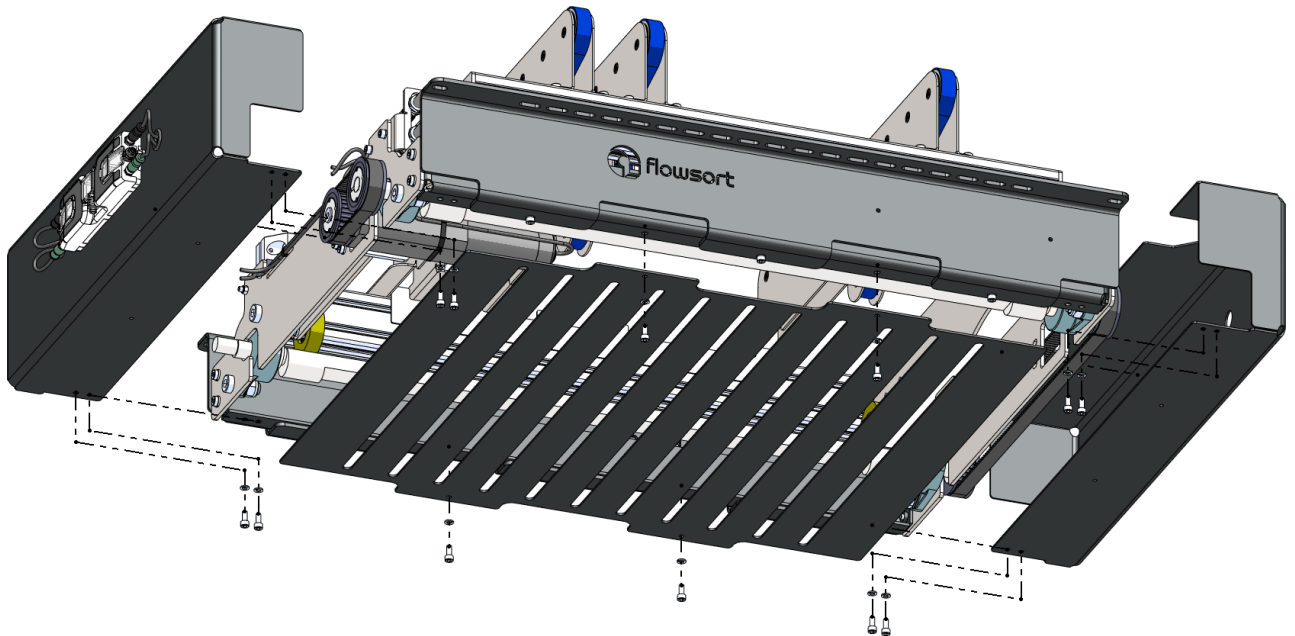

6.6.2 BELT DRIVE UNIT REMOVAL/REPLACEMENT

Step 1

Remove all the 4 M6 screws of the belt drive unit and lift the belt drive off the device.

Step 2

Remove the M6 roll-in T-slot nuts from the aluminium profiles if it is needed by pushing and rolling them. T-slot nuts can be easily slid along the slot in case of relocating a belt drive unit to an adjacent position.

Put the fasteners in a bag not to lose them.

Step 3

Replacing the belt drive units can be done by repeating the steps in reverse order.

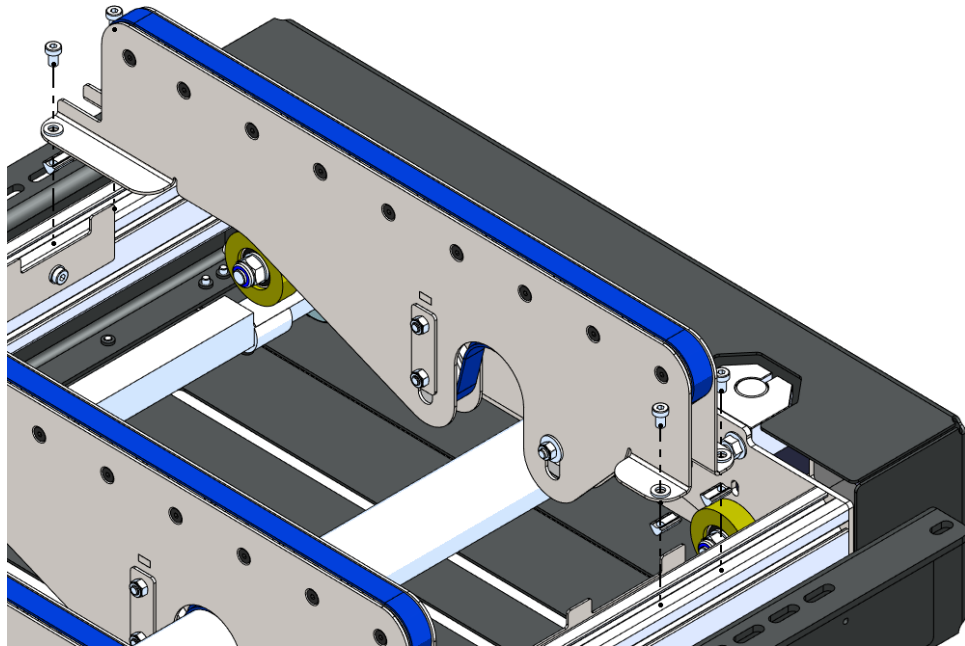

6.6.3 TRANSFER BELT REMOVAL/REPLACEMENT

Before starting with step 1 see chapter 6.6.2 belt drive unit removal/replacement

Step 1

The belt is now free to be removed from the unit.

Step 2

Replacing the belt and the belt drive unit can be done by repeating the steps in reverse order.

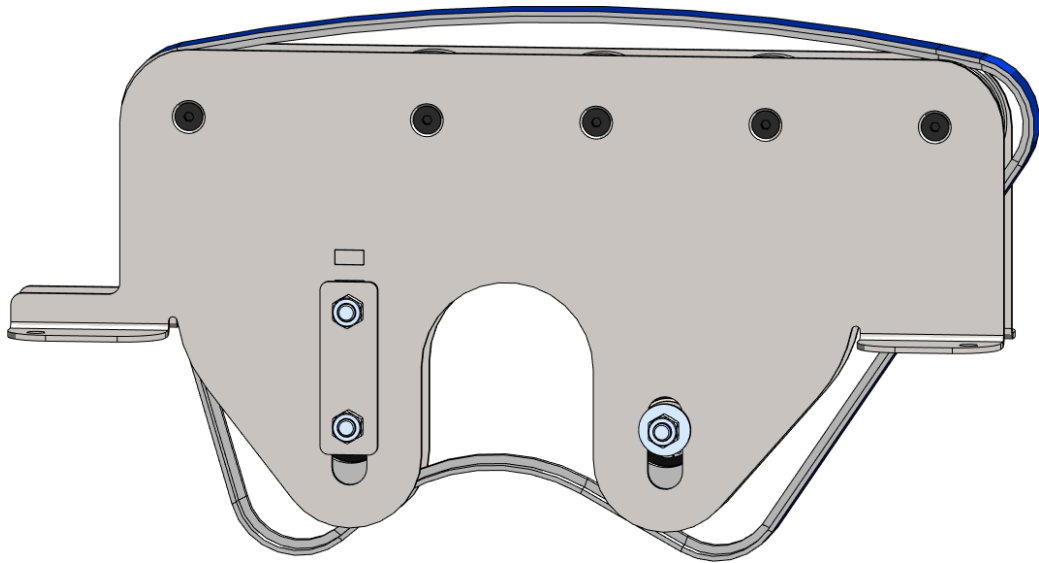

6.6.4 TRANSFER BELT TENSIONING

There is a built-in tensioner mechanism inside the transfer belt unit that can be reached by flipping/lifting the belt on the top. Belt tension can be adjusted by turning the long grub screw with a 3mm hexa key.

Step 1

Loosen the 2 bolts of the tensioner plates.

Step 2

Set the belt tension by turning the grub screw. Increase the tension until you are still able to remove the hexa key easily.

Step 3

Tighten the 2 bolts of the tensioner plates to keep the pre-set tension.

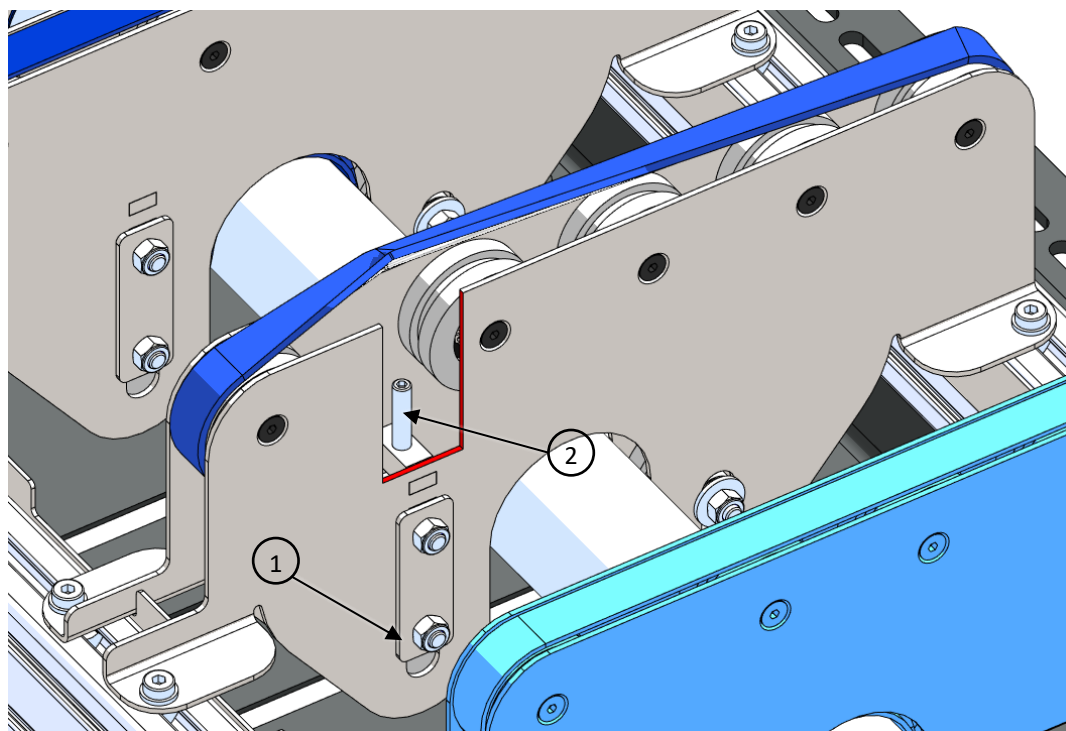

1	tensioner plate
2	grub screw

6.6.5 TAPER BUSH AND TIMING BELT REMOVAL/REPLACEMENT

Before starting with step 1 see chapter 6.6.1 cover removal/replacement.

Removal

Step 1

Remove the 2 screws completely and drive one screw back to the forcing thread.

Step 2

Fasten the screw until the driving element disengages from the bush.

Step 3

Take driving element and bush off the shaft. If necessary, the bush can be forced apart using a screwdriver.

Mounting

Step 1

Clean and degrease all contact surfaces.

Step 2

Set the clamping bush into the hub making sure that all bores align. One threaded bore must always align with one of the smooth half-bores of the counterpart

Step 3

Lubricate the mounting screws and loosely screw in the threads of the component to be mounted.

Step 4

Make sure the keyway of the bush is offset by 180° to the shaft keyway of the motor.

Step 5

Fasten the mounting screws evenly by 5,6 Nm.

Step 6

Alternatively the bush can also be retightened after an operating time of 30 to 60 minutes.

Step 7

Fill the empty holes (used for forcing off) with grease, to protect them against contamination.

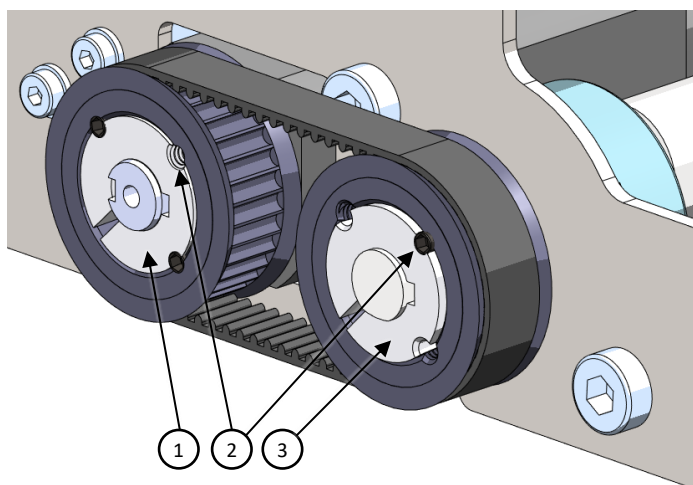

Further details:
[Mädler tutorial video](#)



1	taper bush in locked position
2	force off thread
3	taper bush in open position

6.6.6 LIFT MOTOR REMOVAL/REPLACEMENT

Before starting with step 1 see chapter 6.6.1 cover removal/replacement and 6.6.4 taper bush and timing belt removal/replacement.

Step 1

Remove the sprocket and belt from the motor.

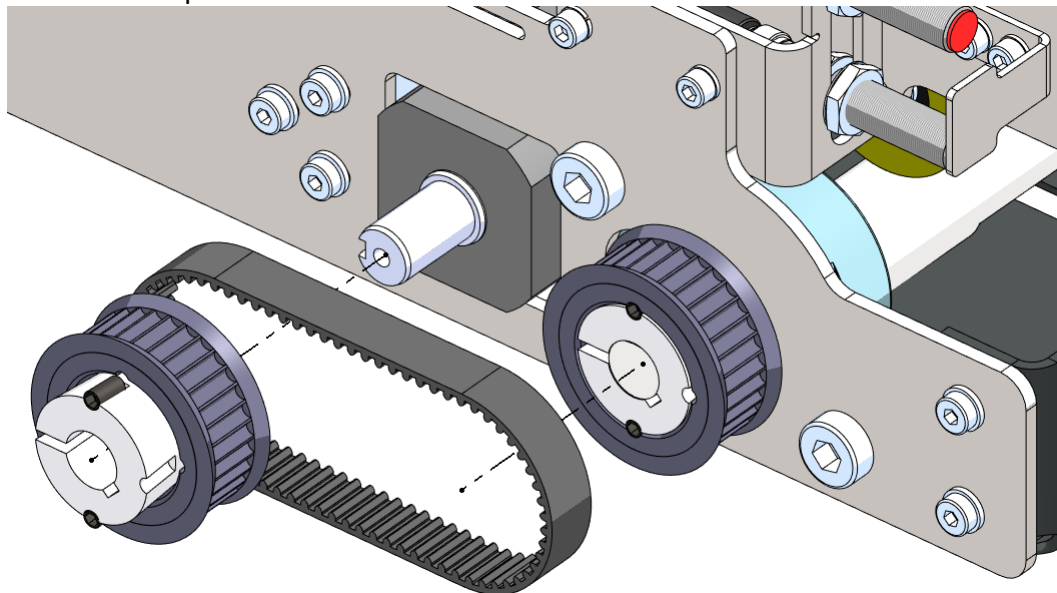

Step 2

Remove all the 2 M5 screws of the motor and remove the motor from the bracket.

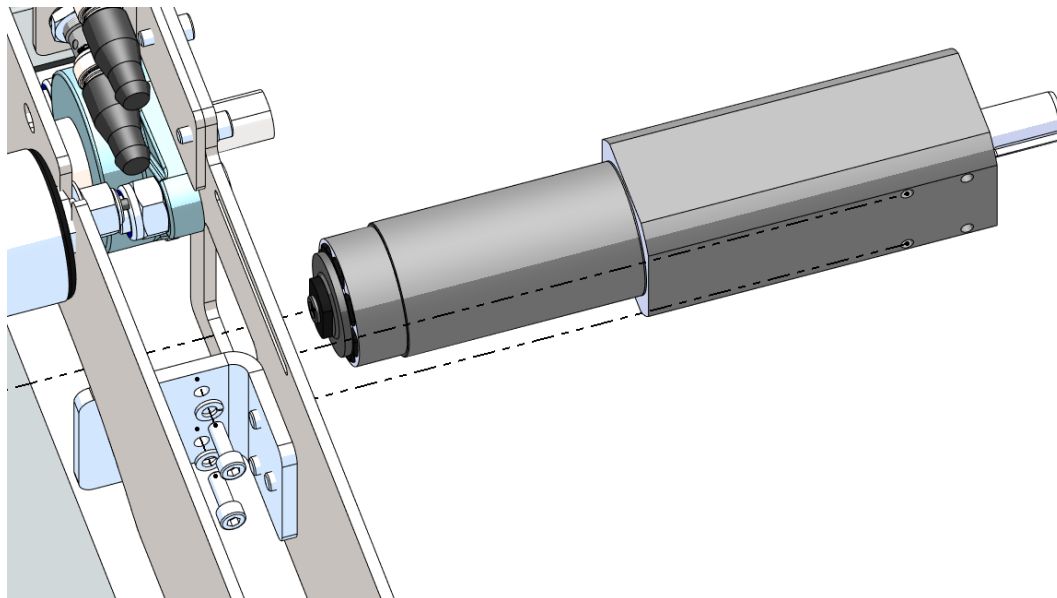

Step 3

Replacing the motor and the belt can be done by repeating the steps in reverse order.

M5 motor screw tightening torque: 3,5Nm

6.6.7 CONTROL CARD REMOVAL/REPLACEMENT

Step 1

Disconnect all cables to the control card. Please keep in mind how the cables are connected to the control card.

Step 2

Untighten all the 2 M5 screws holding the control card.

Step 3

Replacing the control card can be done by repeating the steps in reverse order.

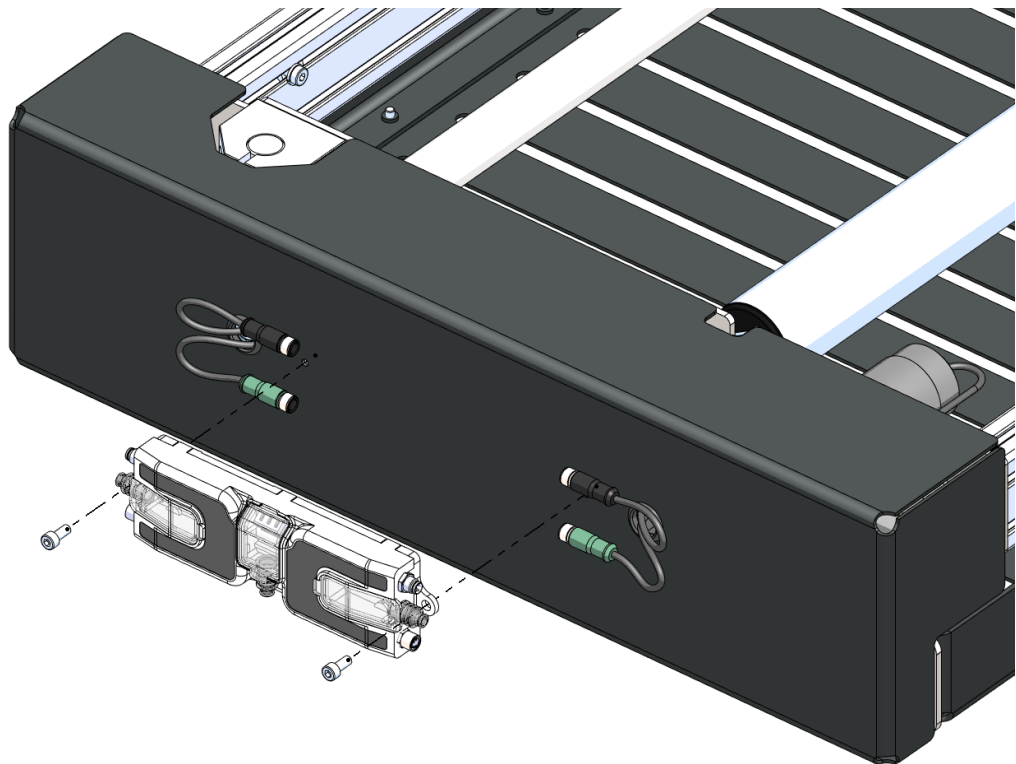

Controller port designation:

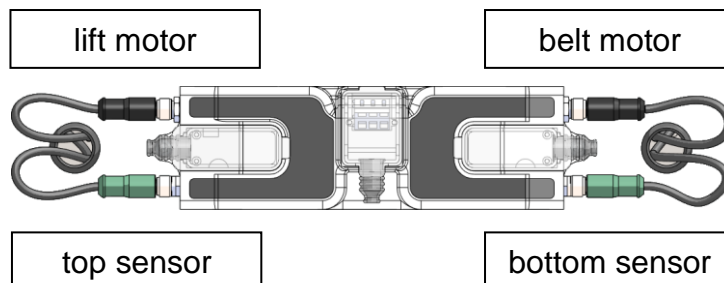

6.6.8 MOTOR DRIVEN ROLLER REMOVAL/REPLACEMENT

Before starting with step 1 see chapter 6.6.1 cover removal/replacement and 6.6.2 belt drive unit removal/replacement.

Step 1

Remove the M12 nut and M8 screw from the shafts of the MDR.

Step 2

Remove the MDR from the assembly upwards.

Step 3

Replacing the MDR can be done by repeating the steps in reverse order.

M12 nut tightening torque: 39-41 Nm

M8 screw tightening torque: 20-22 Nm

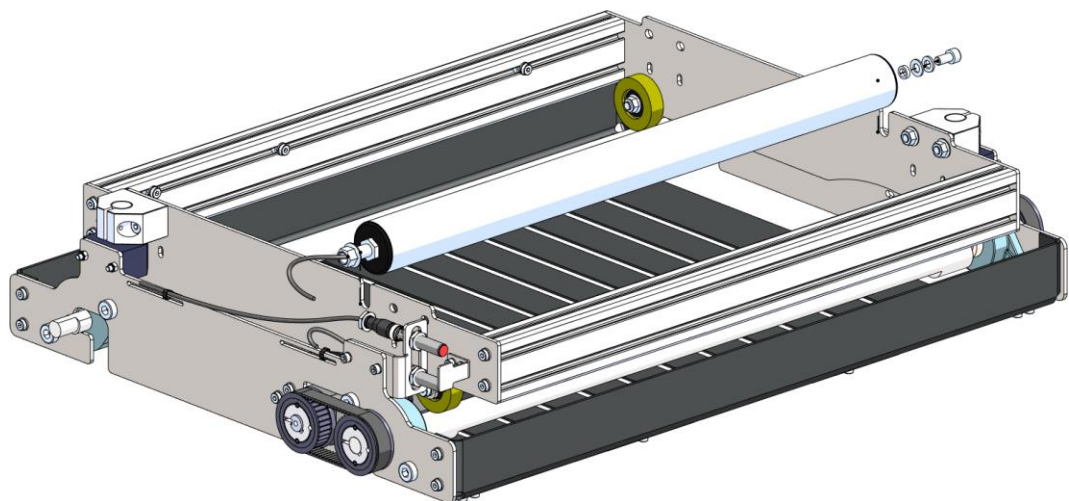

Do not forget to mount the spacer on the M8 screw!

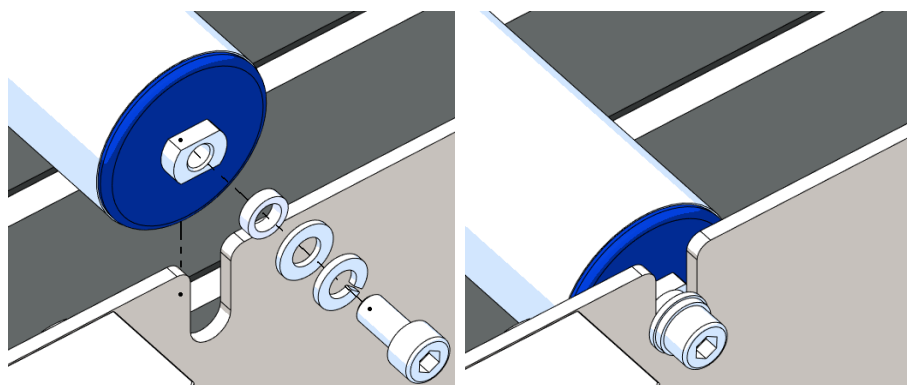

6.6.9 INDUCTIVE SENSOR REMOVAL/REPLACEMENT

Before starting with step 1 see chapter 6.6.1 cover removal/replacement.

Step 1

Disconnect the sensor cable by turning the nut counter clockwise.

Step 2

Use two wrenches for untighten the two M12 nuts holding the inductive sensor on the plate.

Step 3

Replacing the inductive sensor or sensor cable can be done by repeating the steps in reverse order. The distance between the inductive sensor and the counter plate has to be set between **2 - 4 mm**. Make sure that after replacing the sensor cable it does not come close to the timing belt. Secure the sensor cable with tyrap again if it is needed.

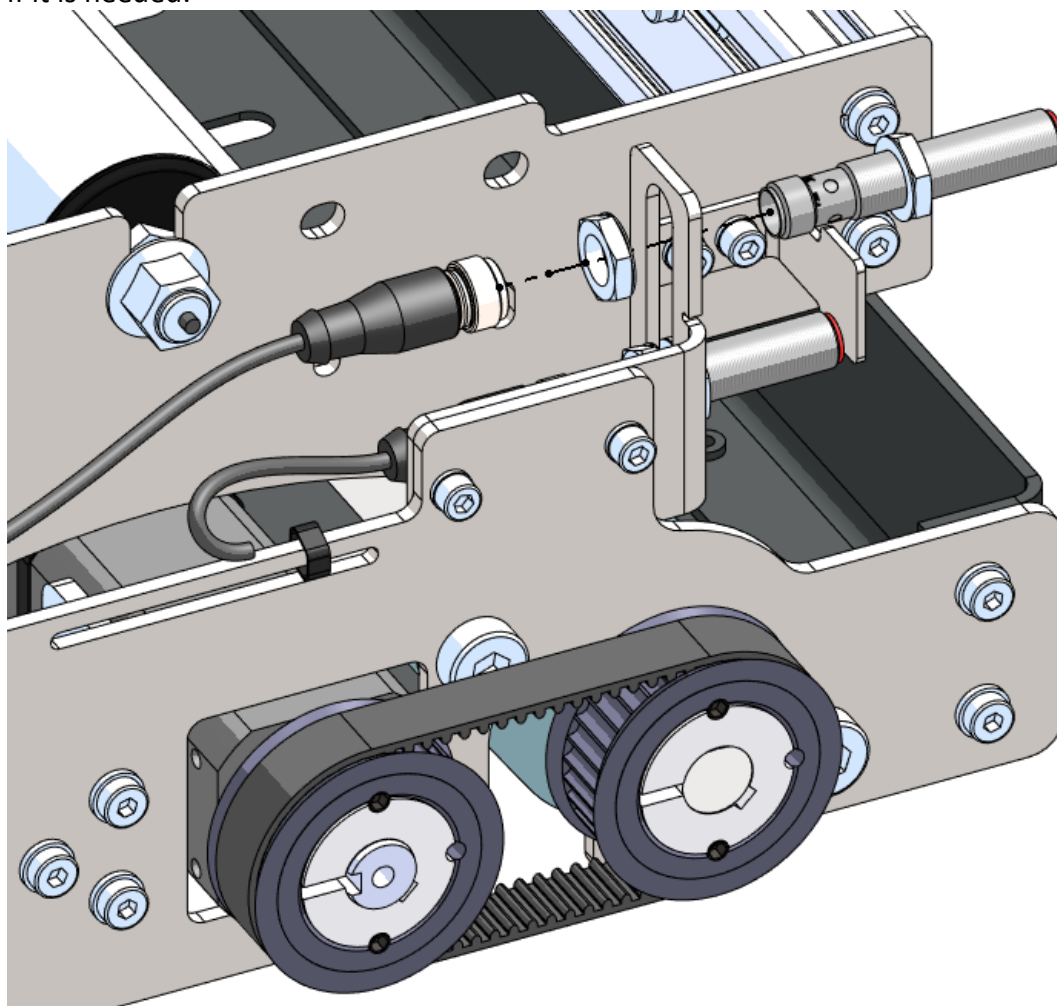

6.6.10 LIFTING WHEEL REMOVAL/REPLACEMENT

Before starting with step 1 see chapter 6.6.1 cover removal/replacement and 6.6.2 belt drive unit removal/replacement.

Step 1

All the belt drive units must be dismantled from the lift mechanism in order to remove weight from the upper assembly of the device.

Step 2

Remove the M8 nut from the wheel axle bolt. The wheel is now free to be removed.

Step 3

Replacing the wheel can be done by repeating the steps in reversed order.

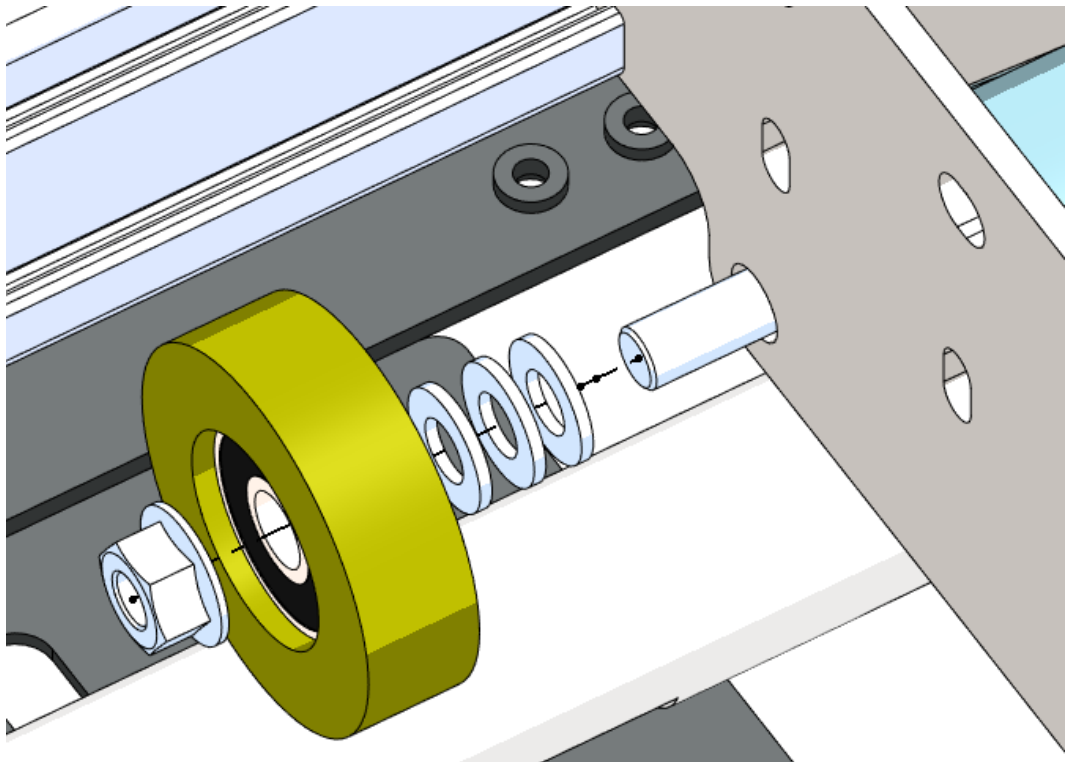

6.6.11 PILLOW BLOCK REMOVAL/REMOVAL

Before starting with step 1 see chapter 6.6.1 cover removal/replacement and 6.6.2 belt drive unit removal/replacement.

Step 1

All the belt drive units must be dismantled from the lift mechanism in order to remove weight from the upper assembly of the device.



Step 2

Make sure that the upper assembly is secured against sideways movement. The assembly becomes unstable when one of the linear guides is removed.

Step 3

Remove the M8 bolts and nuts of the top half of the linear guide set.

Step 4

Remove the M5 bolts and nuts of the pillow block.

Step 5

Replacing the pillow block can be done by repeating the steps in reversed order.

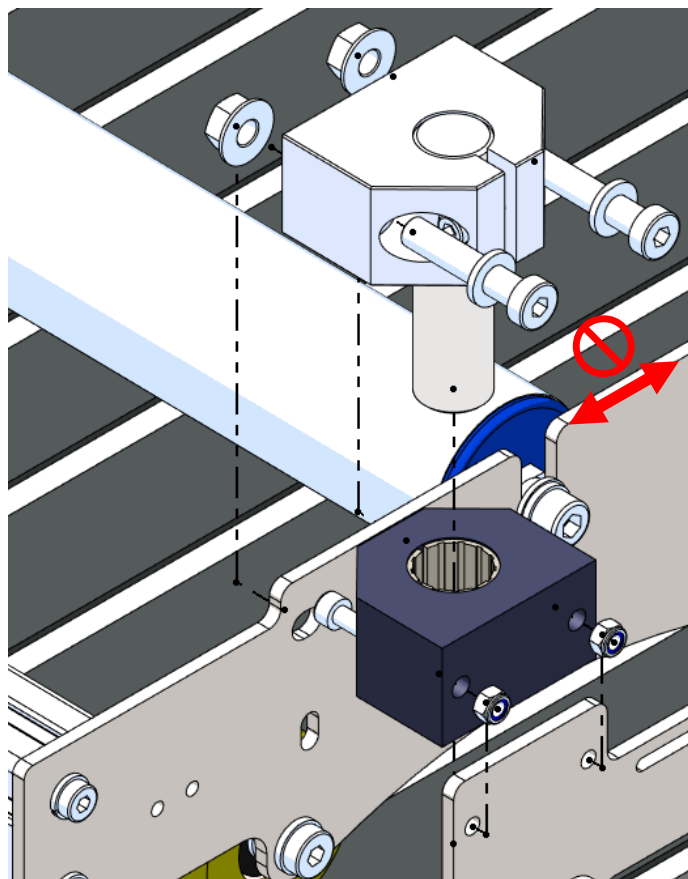

6.6.12 TIMING BELT SYNCHRONIZATION

Before starting with step 1 see chapter 6.6.1 cover removal/replacement and 6.6.4 taper bush and timing belt removal/replacement.

In order to have a smooth and even lifting it is essential to synchronise the 2 excentric shafts.

Step 1

Unlock at least one of the taper bush lock sprockets.

Step 2

Align the flat surfaces of the shafts e.g. with the help of a straight rod or flat bar.

Step 3

Lock the taper bush lock sprockets in position.

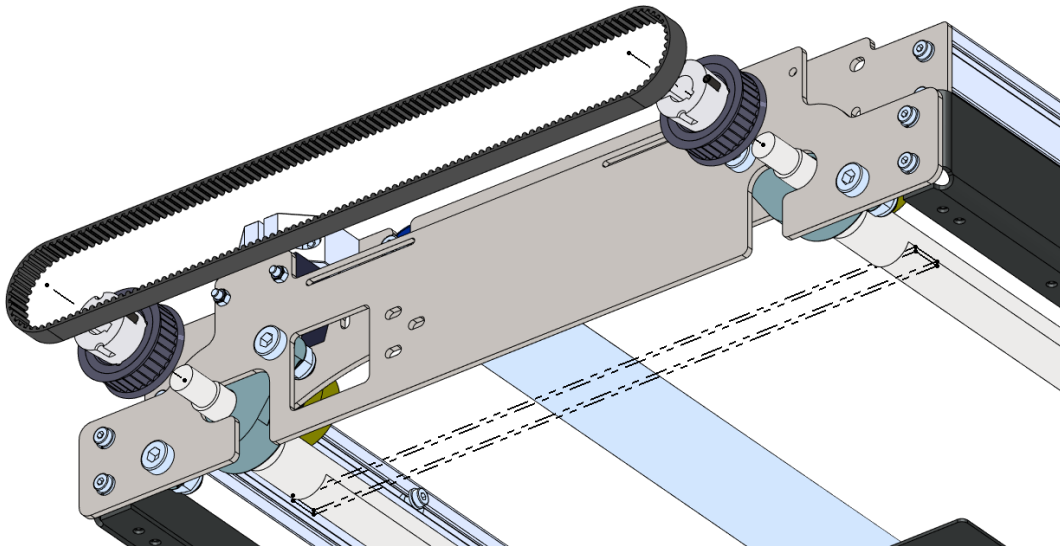

TROUBLESHOOTING

7.1 TROUBLESHOOTING

In case of any issues with the diverters, see the below column to check the possible solution. Also please contact Flowsort in any issue related topic.

Issue	Cause	Avoidance
control card does not work	no power	Check power supply
	no signal inductive sensors	Clean sensor located under the wheel drive assembly with a different colour screw.
	broken inductive sensors	Replace inductive sensor.
	zone controller is broken due damaging or used internal fuse	Replace control card.
control card shows failure	motor is broken due to overheating	Check PGD motor and MDR and if necessary replace the motors.
	tooth wheel of wheel drive assembly is damaged	Replace wheel drive assembly.
	taper bush sprocket is loose	Check the mounting of the sprocket.
	motor is damaged	Replace PGD motor.
	motor cable is damaged	Replace PGD motor.
	control card failure	Check issue "Control card does not work".
	broken excentric shaft	Replace pulley drive assembly.
	timing belt is damaged	Replace the timing belt.
transport belt is not moving	no tension on motor belt	Check the screws of the motor bracket. Re-tension the belt.
	broken inductive sensor	Replace inductive sensor.
	control card failure	Check issue "Control card does not work".
	transport belt is broken	Replace the transport belt.
product flow goes wrong	motor is damaged	Replace MDR.
	motor cable is damaged	Replace MDR.
	unit load is leaving the diverter in the wrong direction	Check software.

DECLARATION OF CONFORMITY

7.2 CE & UKCA CERTIFICATION

Concerning the Machinery Directive 2006/42/EC (appendix II 1 A)

We Flowsort Kft.
Gyár u. 2
2040 Budaörs
Hungary

declare entirely under our own responsibility:

We are the manufacturer of the product:

Mark: **Flowsort**

Type: **X-flow90 24 V**

Function: conveying unit loads

Year of construction:*

Serial no:*

to which this declaration refers.

The machine has additionally been designed and built conforming with the requirements of the supply of Machinery (Safety) Regulation 2008 (UKCA)

The machine meets the requirements of the additional Directives shown below:

Electromagnetic Compatibility Directive 2014/30/EU

Electromagnetic Compatibility Regulations 2016 (UKCA)

The machine has been designed and built in conforming to the European Standards:

EN-ISO 12100-1:2010	Safety of machinery - General principles for design - Risk assessment and risk reduction
EN-IEC 60204-1:2018	Safety of machinery - Electrical equipment of machines - Part 1: General requirements
EN 619:2022	Continuous handling equipment and systems – Safety requirements for equipment for mechanical handling of unit loads
EN-ISO 14120:2015	Safety of machinery - Guards – General requirements for the design and construction of fixed and movable guards

Note: This Declaration does not include all issues concerning the control system, such as: the wiring, programming and supply of control components for this is delivered by another party.

Signed at: Budaörs
Date: 17.12.2024
Signed by: Till Zupancic
Function: Managing Director

Flowsort Kft.
Gyár u. 2
2040 Budaörs
Hungary

